

Gull

Laser Module with ColorDrive



Manual

Written by Stephan Schwarz me

LIVE Lasersystems
Arnethgasse 80
1160 Wien
Österreich

Features

- Easy-to-Integrate With Mounting Bracket
- Output Available From 375nm - 980nm @ 35mW - 7W
- Differential Analog Modulation Input
- High Modulation Frequency 1Mhz (-3db)
- 7 to 25V Input Voltage Range
- Safe Redundant Enable Input
- Output Power Reduction At Excessive And Subnormal Temperatures
- ColorBus Compatible
- Heating And Cooling Capability
- 3s Slowstart (Enable Delay With Softstart)
- High Efficiency
- Dual Voltage Technology
- Accurat Modulation Clipping

Applications

- Laser Show Display Systems
- Industrial Positioning Systems
- DNA Sequencing
- Optogenetics
- And furthermore ...

Description

Modules of the Gull laser module series are optical corrected, capable of high output powers, in a small and easy to integrate form factor.

It accommodates a hermitically sealed optical section that ensures a maintenance free operation over the life of the module.

The thermo electric cooling/heating ensures a wide operating temperature range and a long laser diode life.

ColorBus compatibility ensures easy wiring and multi module integration.

Gull modules use high optical quality components to ensure accurate beam specs.

Information

Every module is handmade to meet high standards at LIVE Lasersystems in Austria.

Modules are shipped ready to use.

They come with all needed wiring harnesses, mounting brackets, drivers and output power measuring protocols.

For OEM modules, please contact LIVE Lasersystems

Technical Drawings:

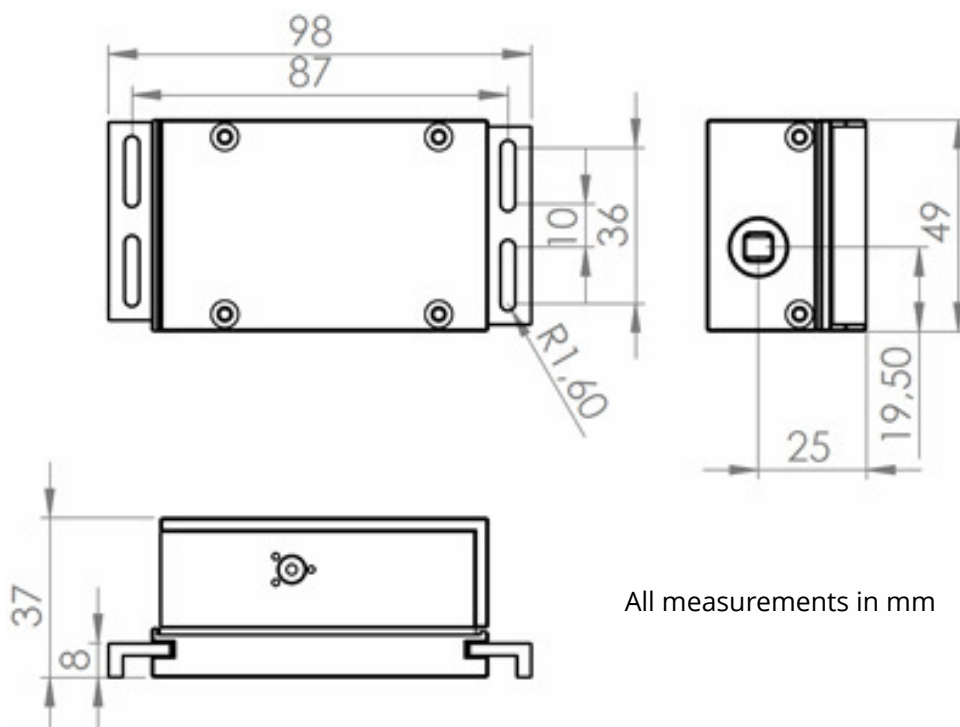

All measurements in mm

Pin Configuration and Functions

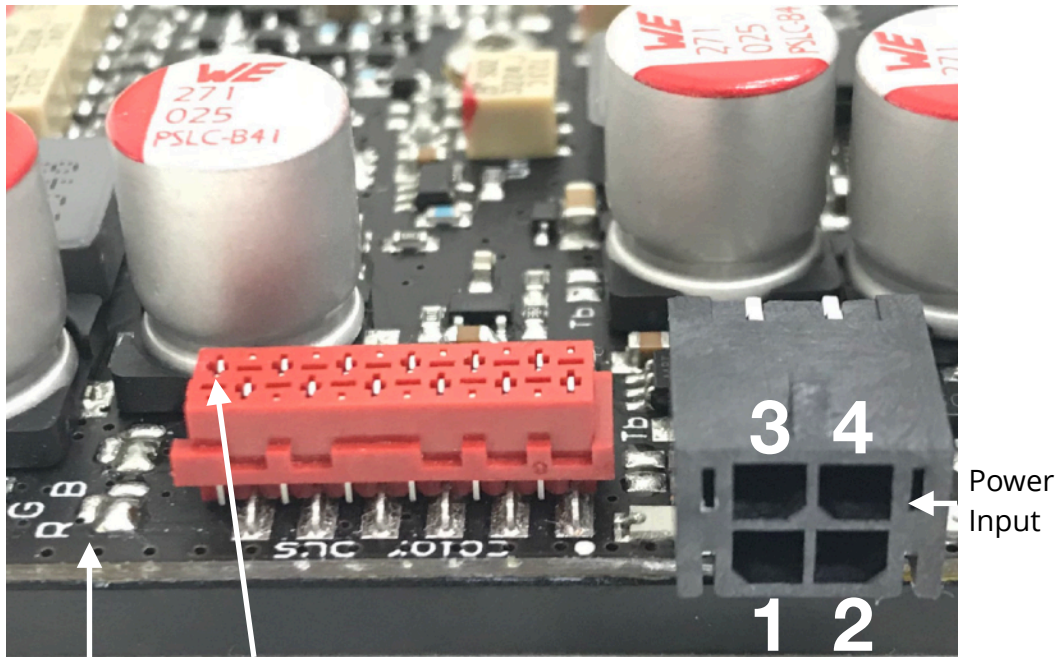

Jumper 1/2 Pin 1 Modulation Input

Power Input Connector

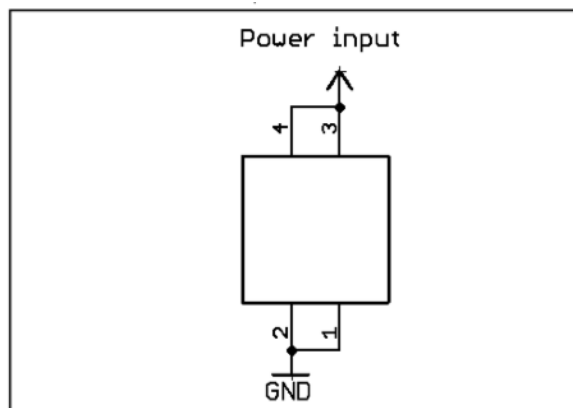

Pin		I/O	Description
No.	Name		
1	GND	I	Negative supply voltage, use both pins if your module is specified with more then 5A current draw.
2	GND	I	Negative supply voltage, use both pins if your module is specified with more then 5A current draw.
3	VCC	I	Positiv supply voltage, use both pins if your module is specified with more then 5A current draw.
4	VCC	I	Positiv supply voltage, use both pins if your module is specified with more then 5A current draw.

Connector style: Würth Elektronik 662004113322 or TE Connectivity

Pin Configuration and Function

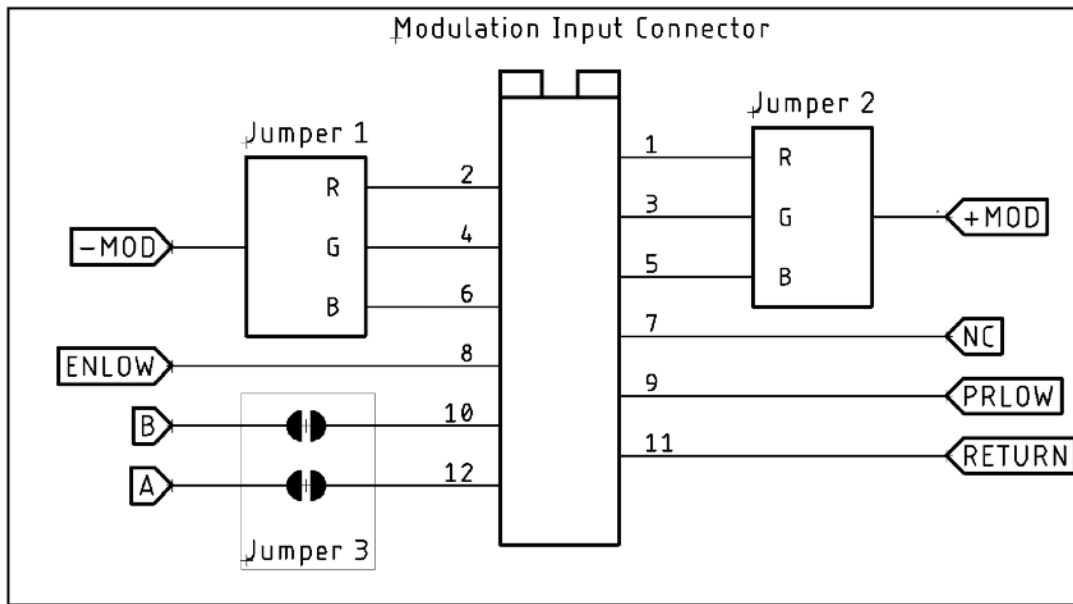

Jumpers: Please consider that the jumpers are preconfigured to match the wavelength e.g. a 638nm red laser module will always use pin 1 and 2 for modulation, a green 520nm module will always ship with jumpers preconfigured to use pin 3/4 as modulation inputs.

You don't need to change the jumpers but you can if you desire so.

Interlock/enable: It is needed to connect pin 8 and pin 11 to operate your laser modules

Modulation Input Connector

Pin		I/O	Description
No.	Name		
1	R+	I	Positive modulation input for laser color RED.
2	R-	I	Negative modulation input for laser color RED.
3	G+	I	Positive modulation input for laser color GREEN.
4	G-	I	Negative modulation input for laser color GREEN.
5	B+	I	Positive modulation input for laser color BLUE.
6	B-	I	Negative modulation input for laser color BLUE.
7	NC	-	Do not connect to anything leave floating.
8	ENLOW	I	Enable input, connect with RETURN (Pin 11) to enable Laser module
9	PRLow	I/O	Power reduction pin, if pulled to RETURN power reduction is enabled. If the driver detects a temperature problem with the module this pin gets internally connected to RETURN.
10	B	O	Output pin for TEC Boosters, not needed for modules.
11	RETURN	-	Return pin for all control signals becomes lowest GND if DVT is used.
12	A	O	Output pin for TEC Boosters, not needed for modules.

Wiring Diagram example

If you want to use your scanner power supply as a power source for your laser modules you can do so by connecting the +24V positive supply to one or more driver, like you normally would. You can also use the negative -24V supply as a power source (pictured below) because the high common mode input voltage of the ColorDrive enables it to function with 0-5V modulation inputs even if its powered from the -24V supply. In this situation it is still possible to use the ColorBus to connect all of your modules in parallel, so all drivers will still react to the Power Reduction signals and enable signals from other drivers even if they are powered by the opposed supply.

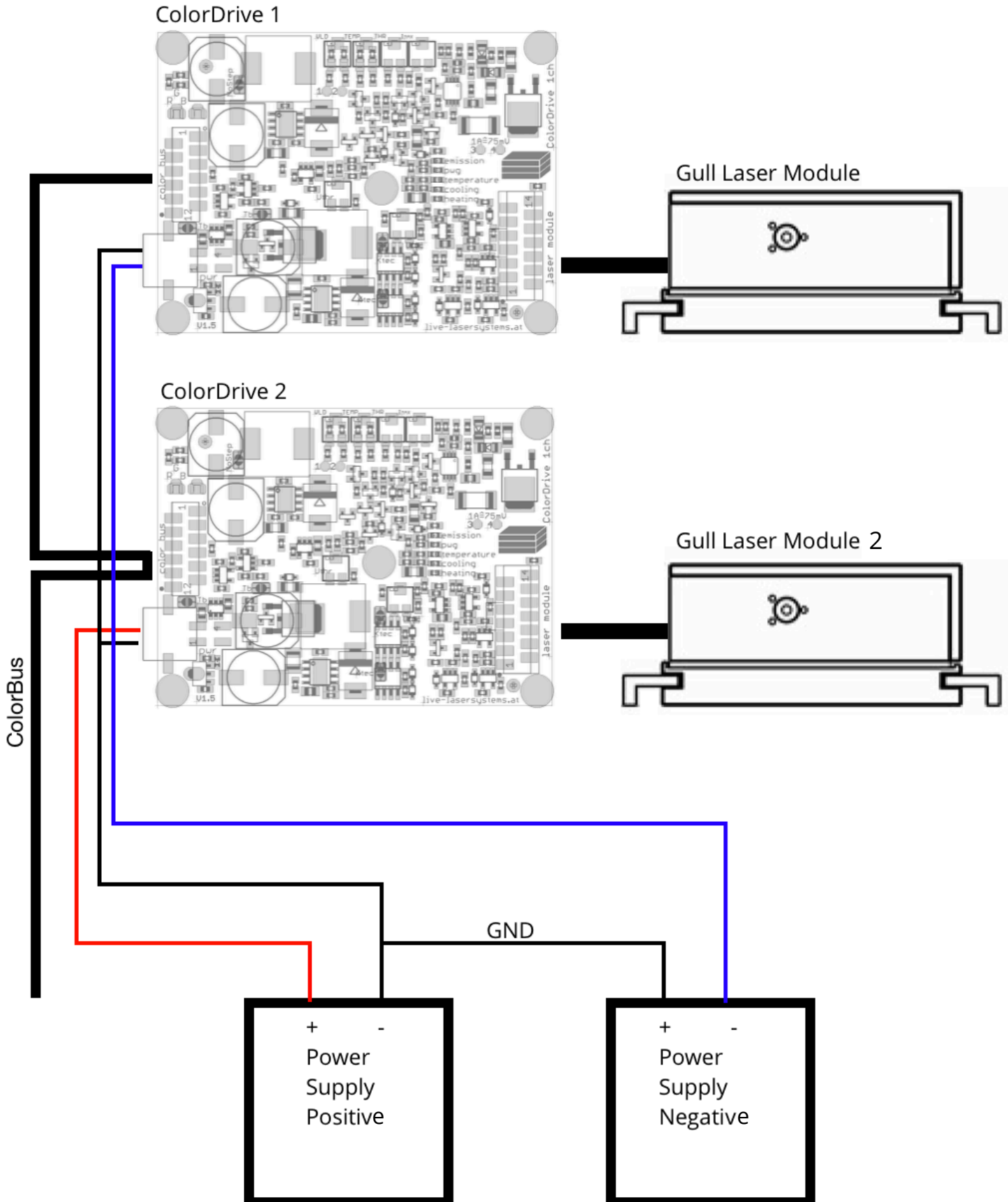

Colordrive

Our laser drivers use step-down technology to ensure low power dissipation at every input voltage. It deploys this technology not only on the laser driver side, but also the built-in TEC driver uses it in both heating and cooling mode thus reducing the needed power to keep a steady temperature at the module and reducing the overall system power dissipation.

Differential Modulation Input

The modulation inputs of Gull modules are equipped with a modulation clipping circuit that protects the diode from current spikes if the input differential voltage exceeds 5V. All Gull laser modules are equipped with differential modulation inputs to allow elimination of all ground loops. Another key feature is the use of Gull modules in dual power supply voltage applications.

Power Reduction

The power reduction feature monitors the temperature of the laser diode and reduces the current flow if the driver detects excessive or subnormal temperatures, thus protecting the diode and elongating its life.

In our standard configuration power reduction will reduce the output power of a connected module by 50%.

Power reduction signals are sent over the ColorBus to enable users to detect such an event and take measures against excessive or subnormal temperatures.

If more than one module is used, all connected modules will receive the information and reduce their power, thus enabling your system to maintain color balance and reducing overall power dissipation.

System Integration

If you have any questions regarding Gull laser modules, their drivers or how to integrate them in a system, don't hesitate contacting LIVE Lasersystems: info@live-lasersystems.at

ColorBus

The ColorBus is a proprietary feature of LIVE Lasersystems laser modules and ColorDrive drivers. It allows to use one ribbon cable with as many crimped on connectors to control as many laser modules as needed.

It transfers the power reduction information to all modules integrated in the system

It has 3 different modulation lines to enable a RGB

Dual Voltage Technologie (DVT)

Our drivers enable you to get the most out of the available power supplies.

It is possible to use dual power supplies (+24V) to power multiple modules and keep one ColorBus for all modules, making it possible to use a galvanometer power supply to power laser modules too.

The high common mode modulation input voltage makes it possible to use the modules on the negative side of the power supply and still use ground oriented modulation signals.

Enable Input

Safety is important for a reliable laser module, therefore LIVE Lasersystems modules use redundant enable inputs.

If a laser module is not enabled there is no laser emission possible, the power of the diode cuts and the modulation signal switches off ensuring no emission in case of a single failure.

Additional Information

Our modules ship with a standard cable length of approx. 25cm between the module and the driver. If longer cables are needed please consider that it is not possible to use longer wires as the driver is not adjusted to match these. There may be problems if longer ones are used. However it is possible to ship modules with longer cables and matching tuned drivers or getting drivers retuned. Please consider there are drawbacks with longer cables like reduced modulation frequency.

Specifications

Absolute Maximum Ratings ⁽¹⁾		Min	Max	Unit
Input Voltage	Power Input connector 3/4	-0,3	25	V
	Modulation connector 8/9	0	+25	
Output Voltage	Modulation connector 8/9	0	5	V
	Modulation connector 11	-25	0	
Source Current	8 ENLOW	495	505	µA
	9 PRLOW	8	9	
Sink Current	8 ENLOW	5	5	mA
	9 PRLOW	5	5	
Differential Input Voltage	Modulation connector 1-6 ⁽²⁾	-30	+30	V
Input Common-Mode Voltage Range	Modulation connector 1-6	-30	+30	V
Input Resistance	Single Ended	68	68,4	kΩ
	Differential	215	220	kΩ
Storage Temperatur		-40	+80	°C
Heatsink Temperatur ⁽³⁾	Module 100% laser output	-50	+55 ⁽⁴⁾	°C
Driver Temperatur	Module 100% laser output	-50	+75	°C

For information on the current draw of the module please look at the shipped measurement protocol.

(1) Stress beyond or at the listed ratings may cause permanent damage to the laser module or driver.

(2) Modulation clipping circuit will activate above 5V differential voltage, causing a useable modulation range of 0-5V.

(3) The maximum heatsink temperature possible, depends on the number of diodes used within the laser module. The stated value is based on a 2W 520nm version of a Gull module. Lower powered modules result in a higher possible temperature maximum. For accurate information on your module contact info@live-lasersystems.at.

(4) Exposure at higher/lower temperatures will cause the activation of the power reduction feature and limit the output power to 50% no damage will occur.

Status LEDs

The modules and the drivers have built-in status LEDs to let the user know their status.

There are 2 LEDs on the front and back of the module itself that shows the enabling status e.g if the driver is enabled and laser emission is possible these will light up.

The driver has 6 LEDs that are labeled accordingly. The table below shows the function associated with them.

LED label	Color	Status if lit	Status if off	Solution
pwr	Green	Driver is powered up	Voltage present on the power input connector.	Use DC power supply to power the module.
emission	Orange	Driver is enabled	Enable lines are not connected.	Tie ENLOW (8) and RETURN (11) together.
			No module connected.	Connect module.
pwg	Green	Driver is enabled and working correctly	Off: driver faulty. (if enable is lit)	Contact LIVE Lasersystems.
			Pulsating: driver too hot.	Bolt the driver to a bigger heatsink.
			Input voltage too low.	Use correct voltage specified on measurement report.
temperature	Yellow	Module temperature not correct	Module temperature regulated correctly	Make sure the heatsink temperature is held within the absolute maximums and wait until module has reached operating temperature.
		NTC/cabling defective		Check cables to module.
cooling	Blue	Driver is cooling the module	The LED shows the required power to keep the module at its operating temperature	Nothing
heating	Red	Driver is heating the module		